

sare®

GLOBAL
High quality Turkish brand

STATIC AND BI DIRECTIONAL TYPE

PILE TESTING SYSTEMS



CE Certificate for
Hydraulic equipments

- POSTTENSIONING SYSTEMS
- GALVANIZED CORRUGATED DUCTS
- PRETENSIONING SYSTEMS
- GROUND ANCHOR SYSTEMS
- MULTI & MONO STRAND JACKS
- INCREMENTAL LAUNCHING EQUIPMENT
- **HYDRAULIC PILE TESTING SYSTEMS** ←



STATIC PILE TESTING JACKS

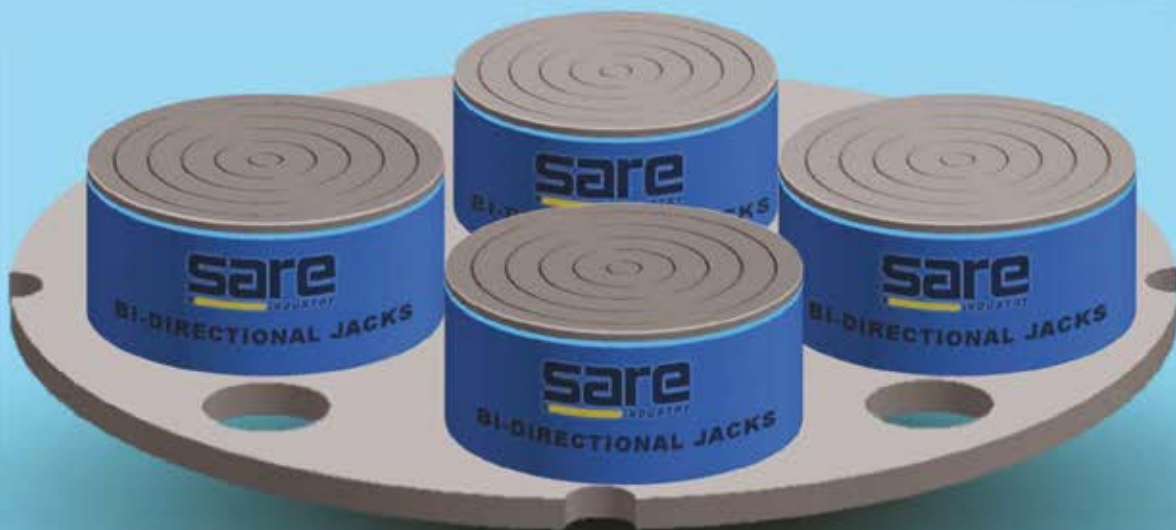

BI DIRECTIONAL JACKS



Bi-Directional Pile Testing Jacks

BI-DIRECTIONAL
PILE TESTING
JACKS



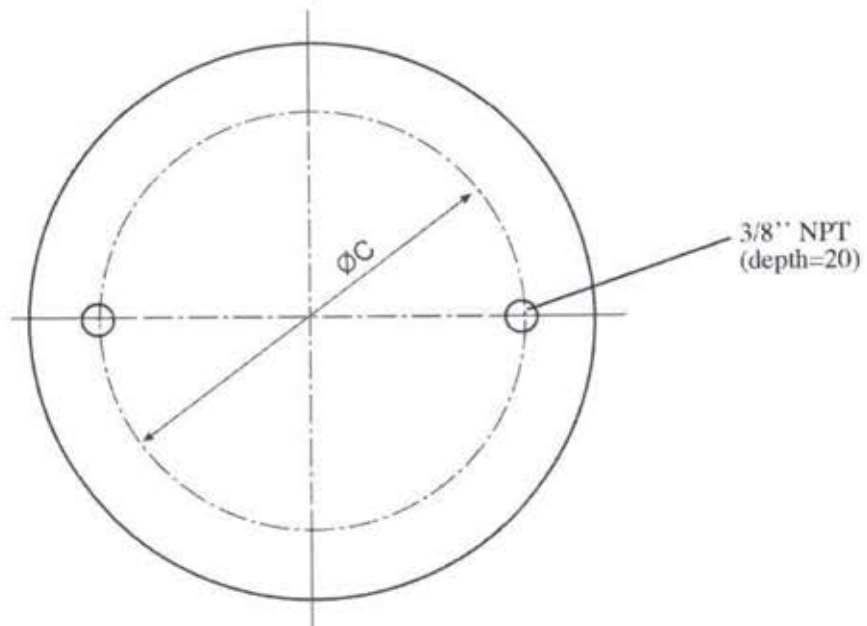
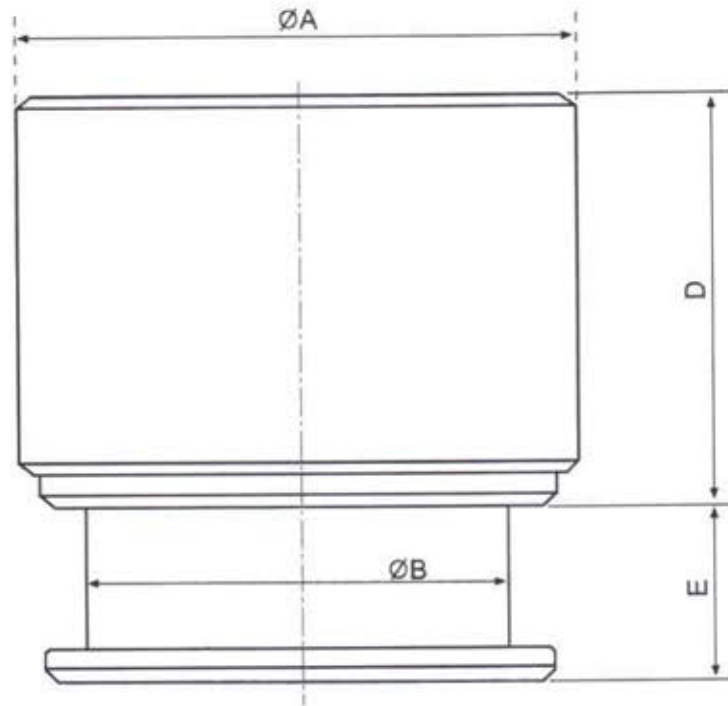



Capacity	A	B	C	D	E	Effective Area	Weight
	outside diameter	piston diameter	port axis diameter	closed height	strok		
ton	mm	mm	mm	mm	mm	cm2	kg.
200	240	190	180	290	165	283,52	104
250	275	215	205	320	165	363,05	151
300	305	235	225	325	165	433,73	189
400	350	270	260	340	165	572,55	264
500	395	300	290	360	165	706,85	348
600	430	330	320	365	165	855,30	419
700	470	360	350	375	165	1.017,87	516
800	500	380	370	385	165	1.134,11	597
900	525	400	390	390	165	1.256,63	670
1000	560	425	415	400	165	1.418,62	765
1200	615	465	455	430	165	1.698,22	1005
1500	685	520	500	465	165	2.123,71	1357

x) Working pressure : 700 bar

x) Test pressure : 800 bar

x) Cylinder calibration certificates will be given along with the jacks.

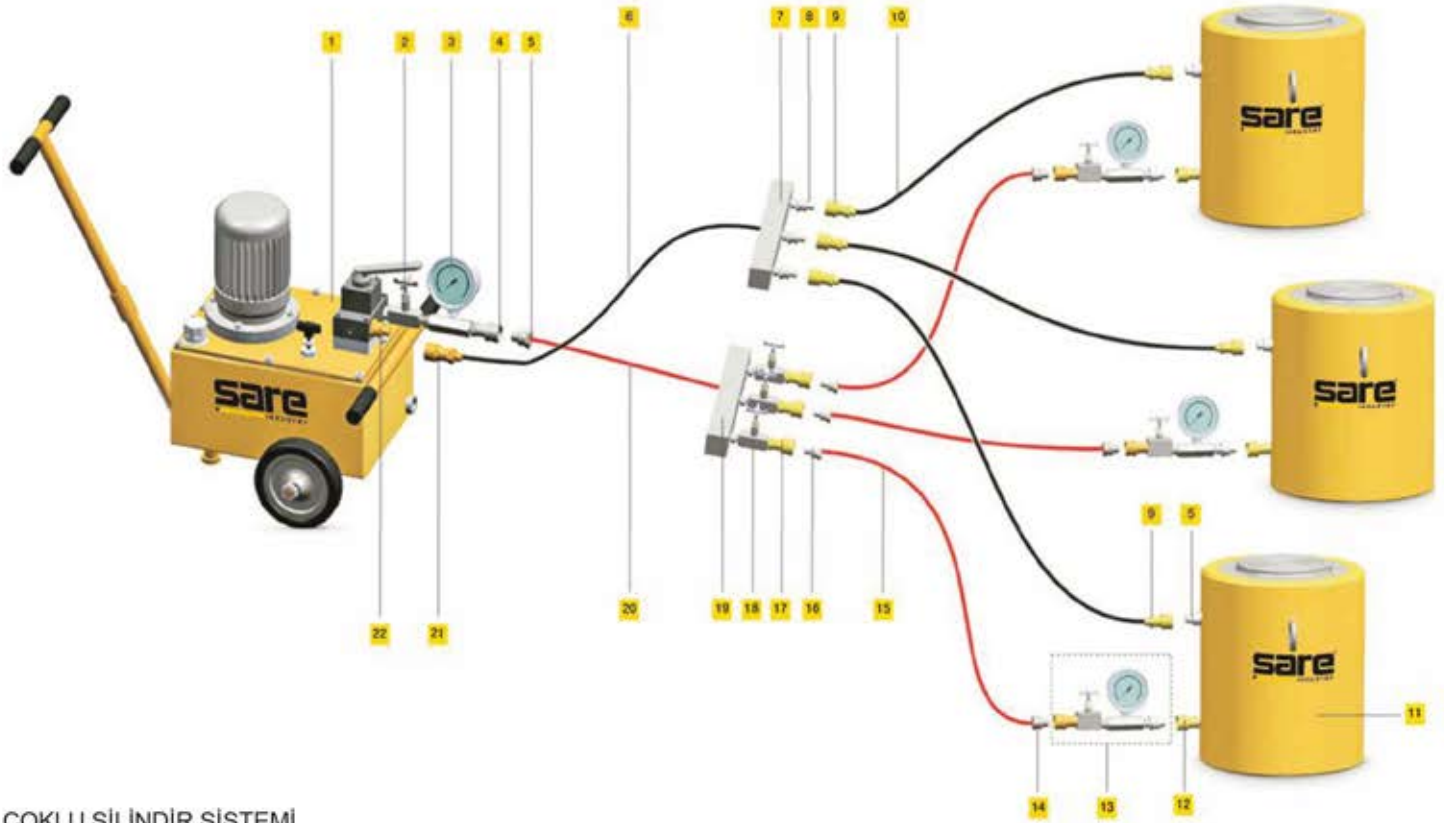

ÇOKLU SİLİNDİR SİSTEMİ
MULTI CYLINDER SET

- | | |
|---|---|
| 1 Elektrikli güç ünitesi
Electric powered pump | 12 Dişi tip çabuk bağlantı rakoru
Female coupler |
| 2 Kademeli yük düşürme valfi
Shut-off valve | 13 Kitleme grubu (Sf:34)
Locking group (Page:34) |
| 3 Ø 100- 0/700 bar gliserinli manometre
Ø 100- 0/700 bar pressure gauge | 14 Erkek tip çabuk bağlantı rakoru
Male coupler |
| 4 Dişi tip çabuk bağlantı rakoru
Female coupler | 15 Basınç hattı hortumu (manifold-silindir)
Pressure line hose (manifold-cylinder) |
| 5 Erkek tip çabuk bağlantı rakoru
Male coupler | 16 Erkek tip çabuk bağlantı rakoru
Male coupler |
| 6 Dönüş hattı, manifold hortumu
Return line manifold hose | 17 Dişi tip çabuk bağlantı rakoru
Female coupler |
| 7 Manifold bloku, dönüş hattı
Return line manifold block | 18 Shut-Off valve
Shut-Off valve |
| 8 Erkek tip çabuk bağlantı rakoru
Male coupler | 19 Manifold bloku, basınç hattı
Pressure line manifold block |
| 9 Dişi tip çabuk bağlantı rakoru
Female coupler | 20 Basınç hattı, manifold hortumu
Pressure line manifold hose |
| 10 Dönüş hattı hortumu(manifold-silindir)
Return line house (manifold to cylinder) | 21 Dişi tip çabuk bağlantı rakoru
Female coupler |
| 11 Kazık yükleme test silindir
Pile test cylinder | 22 Erkek tip çabuk bağlantı rakoru
Male coupler |



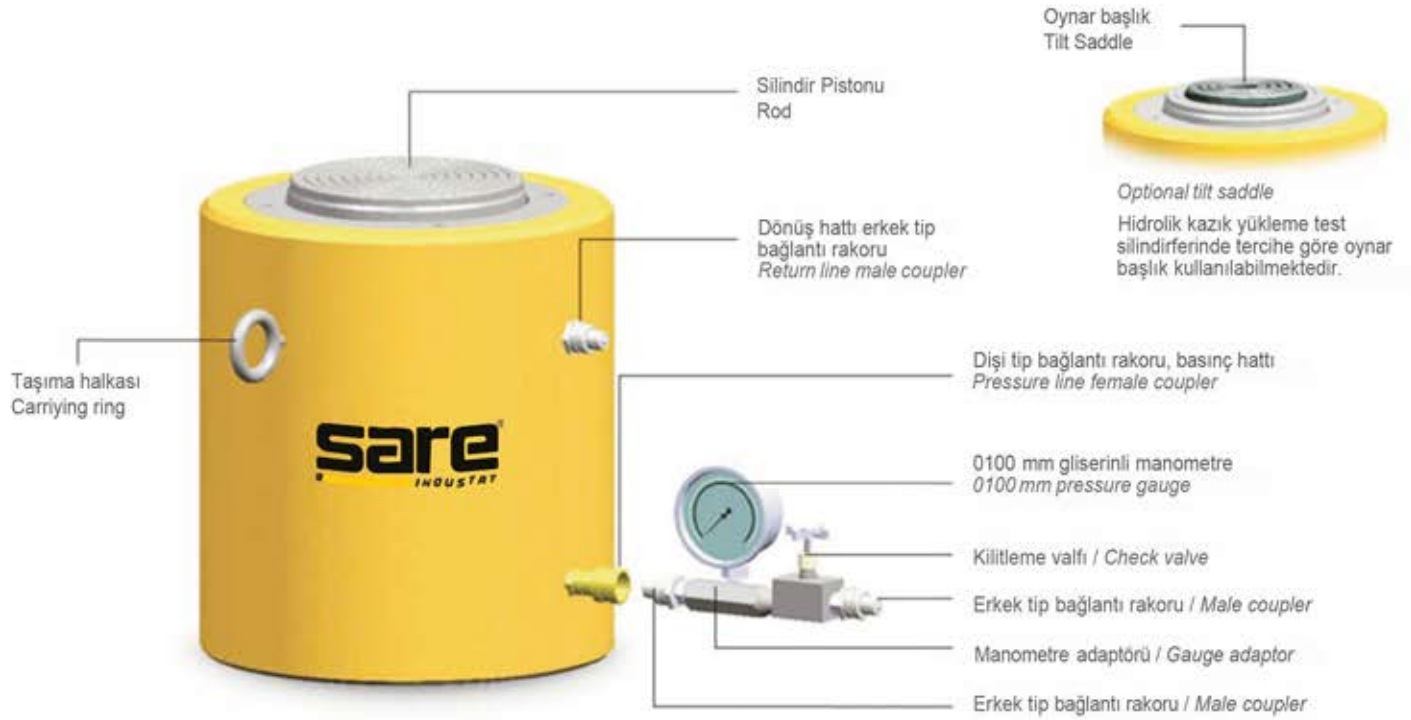

Kilitleme Grubu/ Locking Group

Kazık yükleme testlerinde gerekli uygulama hassasiyetinin sağlanabilmesi için gerek sistemdeki basıncın doğru okunabilmesi, gerekse uygulama güvenliğinin sağlanması üst düzeyde önem arz etmektedir. Hidrolik silindirin basınç hattı girişine monte edilen kilitleme grubu bu iki durumu sağlamaktadır.

In order to supply the necessary operation sensitivity during the pile loading tests, it has utmost importance of correct pressure reading and application security maintenance. The locking group installed on the pressure line port of cylinder enables these two conditions.

1 Silindir içerisindeki basıncı gösteren manometre; Tek ya da çok silindirli uygulamalarda kazığa uygulanan toplam yükü takip edebilmek için kazığa kuvvet uygulayan hidrolik silindirlerin basınçlarını tekil olarak göstermeye yarar. Bu sayede hangi silindirde ne kadar basınç olduğunu öğrenerek o silindire ait kalibrasyon belgesinden uygulanan kuvveti hesaplayabilirsiniz.

Pressure gauge; In single or multi cylindered operations, it maintains to show separately the pressure of hydraulic cylinders applied on pile. So each of the cylinder pressure can be observed and the force applied on that cylinder can be calculated from calibration certificate.

2 Kilitleme valfi; Kazık yükleme uygulamalarında 72 saate kadar yükte bekleme yapılabilmektedir. Bu süre zarfında sistemin herhangi bir noktasındaki olası hortum patlaması, kaçak ya da sızıntılardan testin zarar görmemesi için silindirin basınç hattına monte edilmekte olan bu valf gerek çalışırken gerekse yükte bekleme esnasında hidrolik silindirin içerisindeki basıncı hapseder ve size sadece silindir içerisindeki basıncı okuma imkanı verir.

Locking valve; During this time period, this locking valve is installed to the cylinder pressure line to avoid possible burst at hose in any part of the system and leakage that may give harm to test result. Thus, it locks the pressure in hydraulic cylinder both during operation and waiting period and gives the possibility to read the pressure only in cylinder.



- Silindir kovani alaşımlı çelikten imal edilmiş ve iç yüzeyi honlanmıştır.
- Rod, yüksek alaşımlı çelikten imal edilmiş ve yüzeyi sertleştirilmiştir.
- Rod yüzeyi 100 mikron kalınlığında sert krom kaplanmıştır.
- Pistonda ve boğaz kapagında bronz yataklama yapılmıştır.
- Silindir çıkışlarında hatalı bağlantıyı engelleyen farklı tip çabuk bağlantı rakordan kullanılmıştır.
- Sızdırmazlık elemanları 700 bar basınçta emniyetli çalışabilecek özelliktedir.
- Silindirler, 800 bar çalışma basıncında ve tam strokta test edilmektedir.
- Her bir kazık yükleme silindiri fiili olarak kalibrasyona tabi tutulup, belgelendirilmektedir.

- Cylinder body produced by alloyed steel and inner surface is honed.
- Rod produced by high-alloy steel and case-hardened.
- Rod surface is plated with 100 micron thickness of hard chrome.
- Bronze bearing is done in piston and retaining nut.
- Different types of quick-couples are used to avoid false connection in cylinder ports. Sealing components has characteristic to work at 700 bars safely.
- Cylinders are tested under 800 bar working pressure and exact stroke.
- Each of every pile /loading test cylinder is calibrated and certified

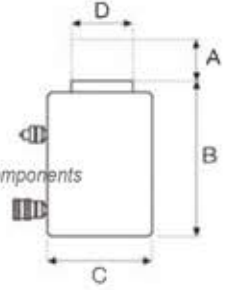

Model No.	Capacity	A	B	C	D	Effective Area	Oil Capacity	Weight
		Stroke	Closed Height	Outside Diameter	Rod Diameter			
	ton	mm	mm	mm	mm	cm ²	cm ³	kg
PTH-20015	200	150	330	260	150	283,40	2650	123
PTH-20020		200	380				3533	140
PTH-20025		250	430				4416	157
PTH-30015	300	150	360	320	185	433,50	4030	204
PTH-30020		200	410				5373	230
PTH-30025		250	460				6717	256
PTH-40015	400	150	405	380	215	572,30	5444	330
PTH-40020		200	455				7258	366
PTH-40025		250	505				9073	402
PTH-50015	500	150	440	420	240	706,50	6783	434
PTH-50020		200	490				9043	479
PTH-50025		250	540				11305	524
PTH-60015	600	150	465	470	260	854,90	7962	575
PTH-60020		200	515				10616	630
PTH-60025		250	565				13270	685
PTH-80015	800	150	490	530	300	1133,55	10598	770
PTH-80020		200	540				14131	840
PTH-80025		250	590				17664	910
PTH-100015	1000	150	545	610	360	1451,50	15262	1165
PTH-100020		200	595				20348	1263
PTH-100025		250	645				25435	1361



EPP Serisi Elektrikli Güç Ünitesi

EPP Series Electric Power Pack

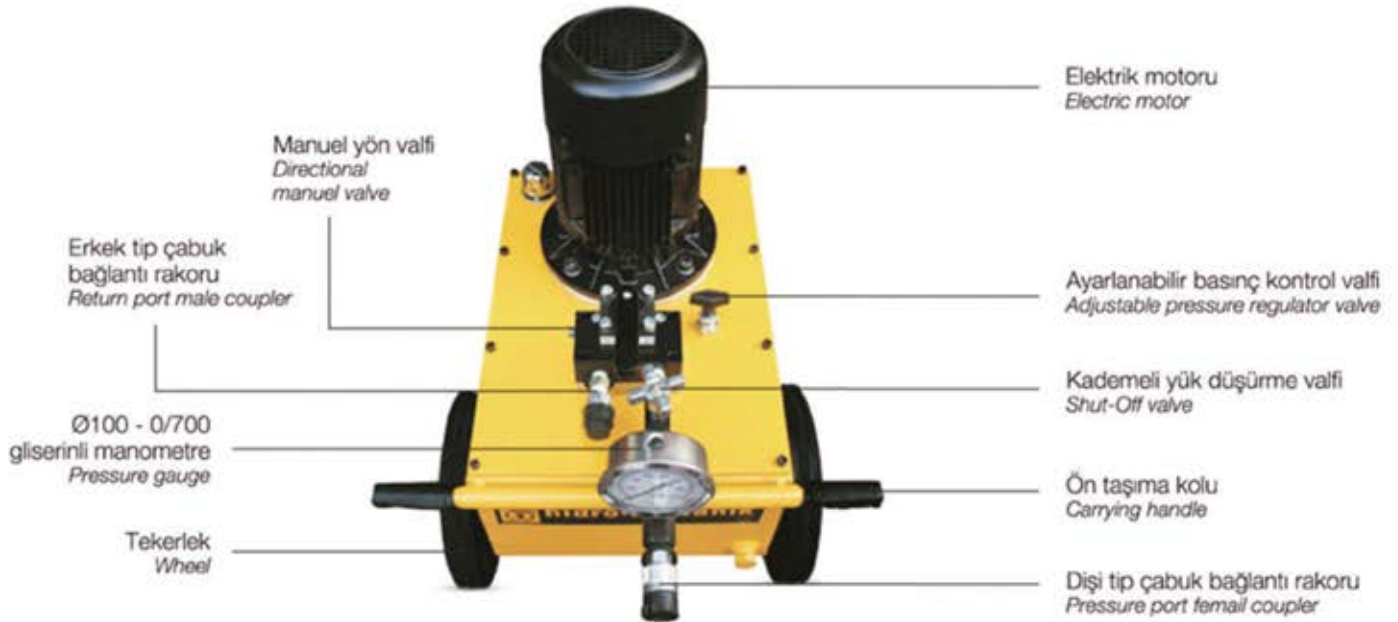



Power Unit Model No.		EPP-257	EPP-367	EPP-507	EPP-667	EPP-807
Power Pump Type		Single Stage Special Design for Pile Testing Applications				
Pump Type		Radial 3 Piston Pump		Radial 5 Piston Pump		Radial 7 Piston Pump
Working Pressure (Max.)	bar	700				
Displacement	l/min	2,5	3,6	5,0	6,6	8
Motor Power	kw	3	4	5,5	7,5	9
Motor Rpm	rpm	1400				
Reservoir Capacity	liter	32	60	87	120	158
Usable Oil Capacity	liter	25	48	70	96	130
Reservoir Sizes	mm	330 x 450 x 230	410 x 560 x 260	480 x 660 x 280	550 x 750 x 300	600 x 820 x 330
Pressure Gauge		G-7: 100 mm x 0-700 bar (glycerine filled) & GD-1: 64 mm x 0-700 bar Digital				
Return Line Pressure	bar	150				
Directional Control Valve		4 Way - 3 Position Manual				
Pressure Control Valve		20 - 700 bar Adjustable Pressure Regulator Valve				
Motor Specifications		220/380 V., 50 Hz., 3-Phase				
Motor Remote Control		Start / Stop - With 3 Meter Cord				
Wheel Diameter	mm	250	300	300	350	350
Weight	kg	90	131	178	231	282

OSB Serisi Oynar Başlık

OSB Series Tilt Saddle



- Opsiyonel
- Dik olmayan yükler için
- 5° maksimum hareket açısı
- *Optional*
- *Recommended for use under side load forces*
- *Inclination of 5° is accepted*

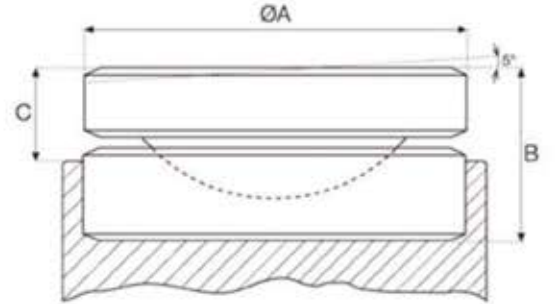

Model No.	Cylinder Capacity	A	B	C	Weight
	ton	mm	mm	mm	kg
OBP-200	200	111	52	40	4,2
OBP-300	300	131	57	45	6,5
OBP-400	400	178	67	47	13,5
OBP-500	500	200	79	57	20,5
OBP-600	600	220	90	67	30,5
OBP-800	800	250	105	75	41
OBP-1000	1000	310	160	115	105

MD Serisi Manifold Sistemleri

MD Series Manifold Systems for Pressure Line

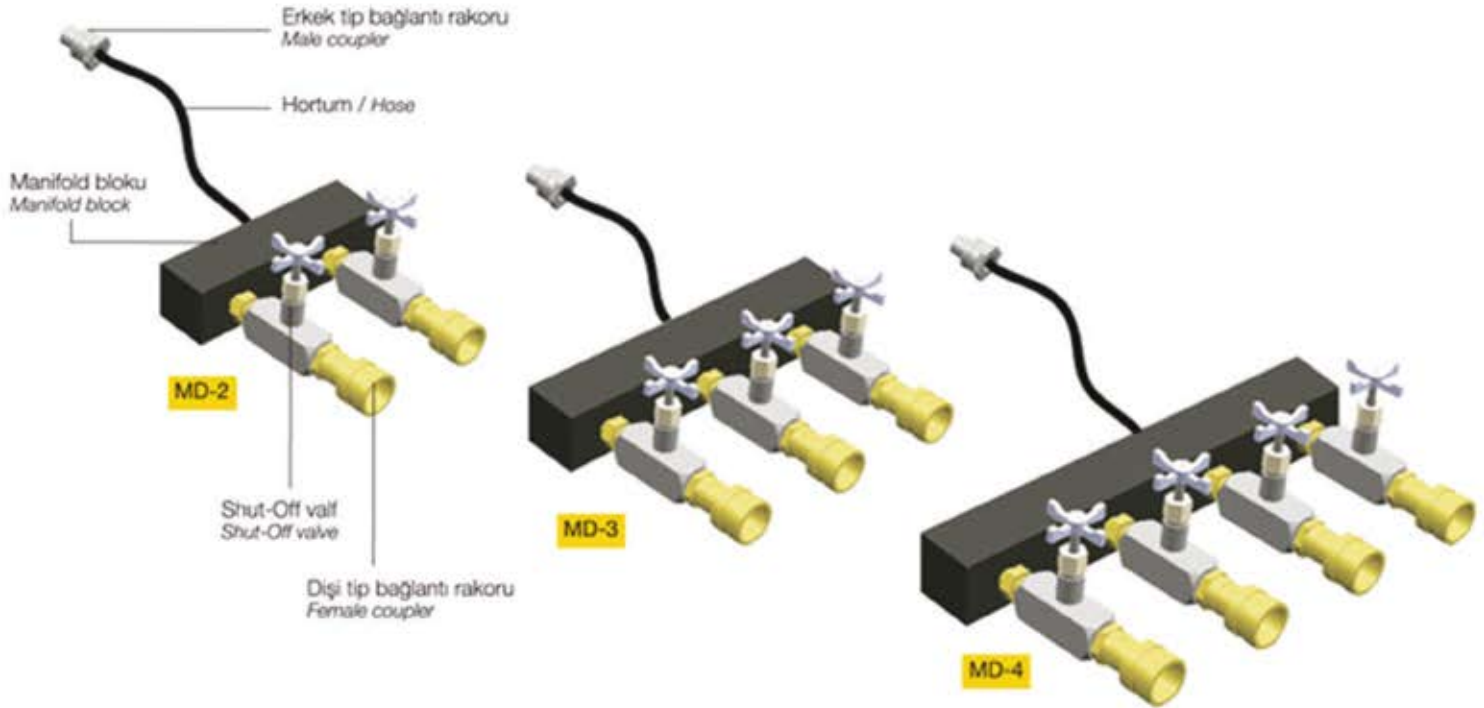
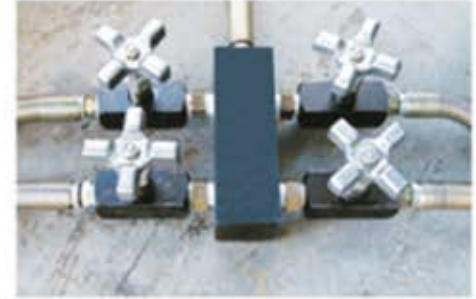

Model No.	Manifold Type	Valve Type	Port Pcs	Dimensions	Working Pressure	Weight
				mm	bar	kg
MD - 2	Manifold System for Pressure Line	Shut-Off valve	2	50x50x215	700	6,10
MD - 3			3	50x50x295		8,40
MD - 4			4	50x50x370		10,70

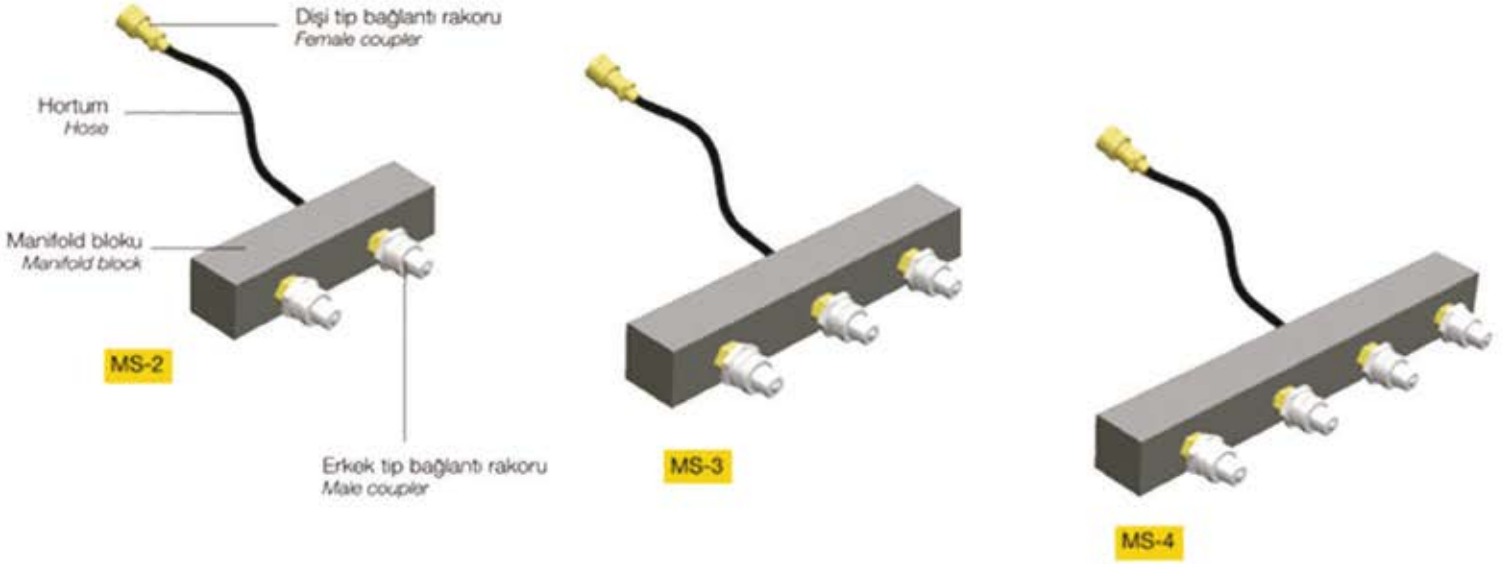

MS Serisi Manifold Bloklar

MS Series Manifold Blocks for Return Line



Model No.	Manifold Type	Port Pcs	Dimensions	Working Pressure	Weight
			mm	bar	kg
MS - 2	Manifold System for Return Line	2	50x50x175	700	4,10
MS - 3		3	50x50x235		5,30
MS - 4		4	50x50x295		6,50

Hortumlar / Hoses

	Model No.	Length	Internal Diameter	Weight
		m	mm	kg
 Basınç hattı bağlantı hortumu Pressure line hose with male coupler	HS - 2208	8	6,40	4,10
	HS - 2210	10		5,00
 Dönüş hattı bağlantı hortumu Return line hose with female coupler	HS - 2212	12		5,90
	HS - 2215	15		7,25

Çalışma basıncı / Working pressure : 700 bar
 Patlama basıncı / Burst pressure : 2170 bar

Basınç hattı hortumlarının iki ucuna erkek tip bağlantı rakoru, dönüş hattı hortumlarının iki ucuna dişi tip bağlantı rakoru monte edilmiştir.

Manometreler / Pressure Gauges

	Model No.	Capacity	Scale Diameter	Oil Port	Gauge Type
		bar	mm		
 G7	G7	0-700	100	1/4" NPT	Glycerine Filled
	GD1		63		Digital

Çabuk Bağlantı Rakorları / Couplers

	Model No.	Description	Weight
			kg
 C-213 C-211	C-213	Coupler half, male with 3/8" NPT inner connection thread	0,150
	C-211	Coupler half, female with 3/8" NPT outer connection thread	0,225
	C-209	Coupler complete	0,375